

LOCATION OF JOINTS IN CONCRETE SIDEWALK

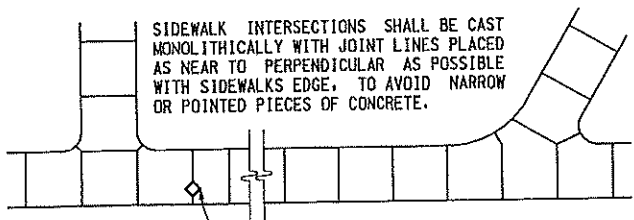

WHERE A PERMANENT STRUCTURE IS LOCATED IN SIDEWALK, PLACE EXPANSION MATERIAL AROUND STRUCTURE AND ADJUST JOINT PATTERN TO INTERSECT STRUCTURE AS ILLUSTRATED.

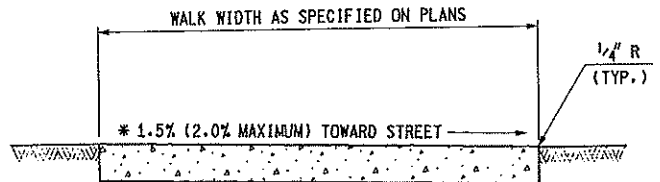

* SEE NOTES

TYPICAL SIDEWALK JOINT LAYOUTS

4" CONCRETE SIDEWALK



PREPARED BY
DESIGN DIVISION

DRAWN BY: B.L.T.
CHECKED BY: W.K.P.

DEPARTMENT DIRECTOR
Kirk T. Steudle

APPROVED BY: Randy Van Pelt
DIRECTOR, BUREAU OF FIELD SERVICES

APPROVED BY: Mark A. Van Pelt
DIRECTOR, BUREAU OF HIGHWAY DEVELOPMENT

MICHIGAN DEPARTMENT OF TRANSPORTATION
BUREAU OF HIGHWAY DEVELOPMENT STANDARD PLAN FOR

**DRIVEWAY OPENINGS
& APPROACHES,
AND CONCRETE SIDEWALK**

9-30-2014
F.H.W.A. APPROVAL

7-1-2014
PLAN DATE

R-29-I

SHEET
1 OF 4

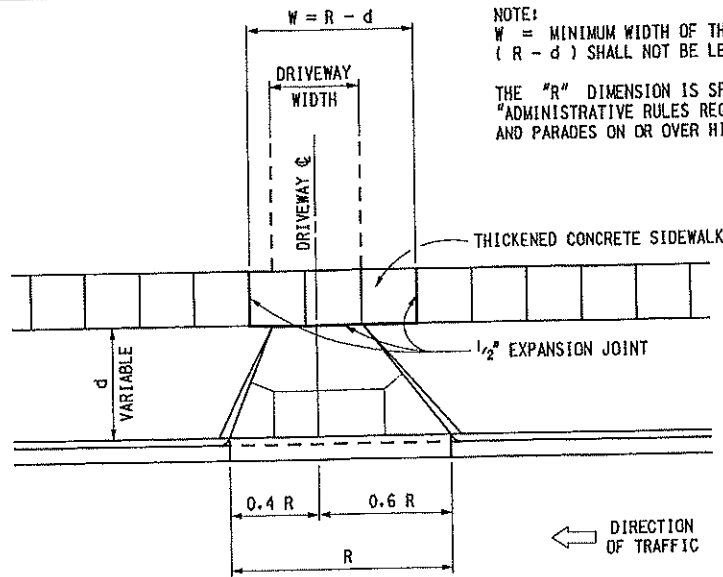

NOTE:
 W = MINIMUM WIDTH OF THICKENED CONCRETE SIDEWALK.
 $(R - d)$ SHALL NOT BE LESS THAN DRIVEWAY WIDTH.

THE "R" DIMENSION IS SPECIFIED IN THE PUBLICATION
 "ADMINISTRATIVE RULES REGULATING DRIVEWAYS, BANNERS
 AND PARADES ON OR OVER HIGHWAYS".

CONCRETE DRIVEWAY OPENING LAYOUT

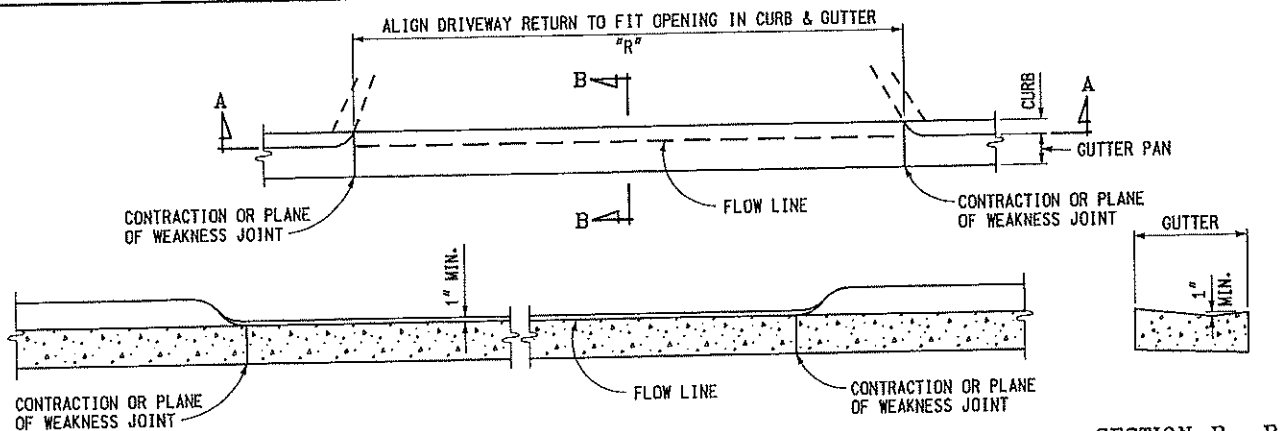

SECTION A - A
 CONCRETE DRIVEWAY OPENING, DETAIL L

SECTION B - B

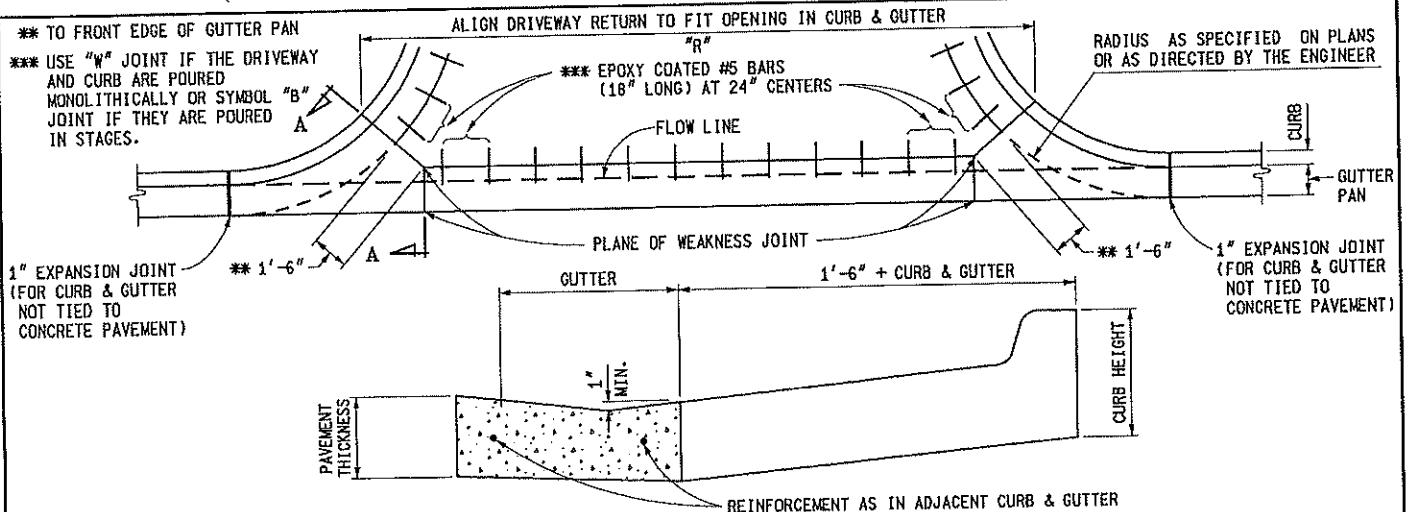

SECTION A - A
 CONCRETE DRIVEWAY OPENING, DETAIL M

NOTE:
 FOR ROADWAYS WITH CONCRETE PAVEMENTS, LONGITUDINAL LANE TIES WILL
 BE CONTINUOUS THROUGH THE DRIVEWAY OPENING AND THE SPACING OF THE
 #5 BARS IN CONCRETE DRIVEWAYS SHALL BE ADJUSTED TO AVOID CONFLICT
 WITH THE LONGITUDINAL LANE TIES.

MICHIGAN DEPARTMENT OF TRANSPORTATION
 BUREAU OF HIGHWAY DEVELOPMENT STANDARD PLAN FOR

DRIVEWAY OPENINGS
 & APPROACHES,
 AND CONCRETE SIDEWALK

9-30-2014 F.H.W.A. APPROVAL	7-1-2014 PLAN DATE	R-29-I	SHEET 2 OF 4
--------------------------------	-----------------------	--------	-----------------

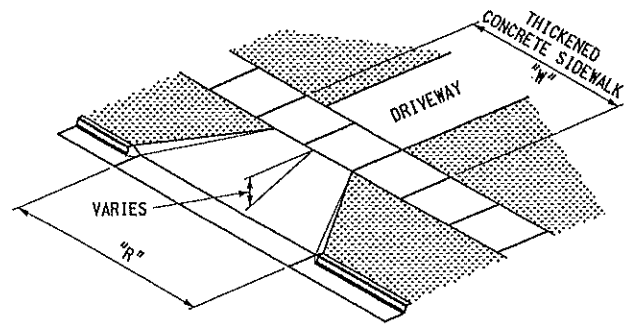
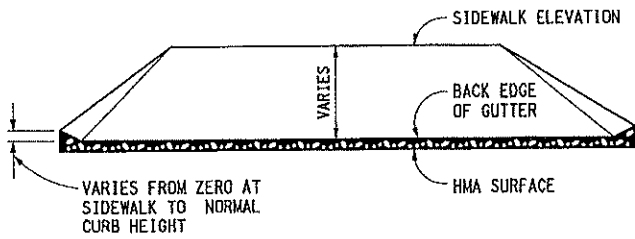

HMA DRIVEWAY APPROACH
(TO BE USED WITH DETAIL L)

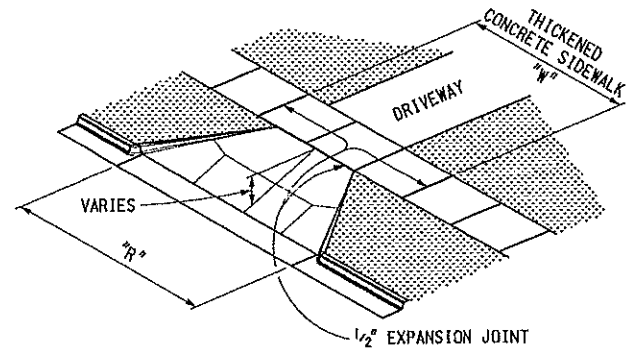
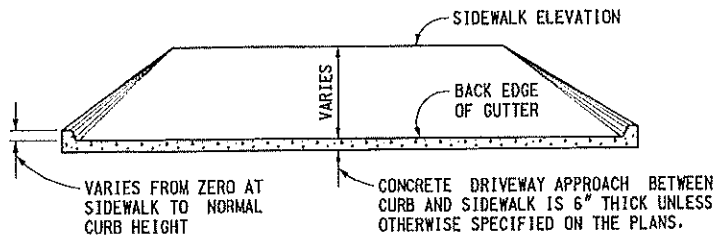

NOTES:

MONOLITHIC CURB IS INCLUDED IN THE CONCRETE DRIVEWAY APPROACH QUANTITY.

REINFORCEMENT IS NOT REQUIRED UNLESS SPECIFIED ON THE PLANS. WHEN REINFORCEMENT IS SPECIFIED, SEE CHART ON THIS SHEET.

CONCRETE DRIVEWAY APPROACH
(TO BE USED WITH DETAIL L OR M)

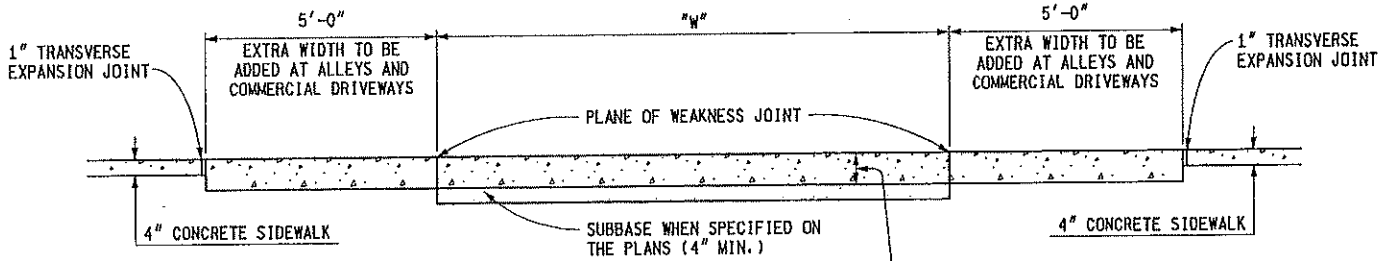

WHEN CONCRETE DRIVEWAY APPROACH IS SPECIFIED, THE THICKENED CONCRETE SIDEWALK THICKNESS IS EQUAL TO THE THICKNESS OF THE CONCRETE DRIVEWAY APPROACH. WHEN HMA DRIVEWAY APPROACH IS SPECIFIED, THE THICKENED CONCRETE SIDEWALK THICKNESS IS 6" MIN.

THICKENED CONCRETE SIDEWALK

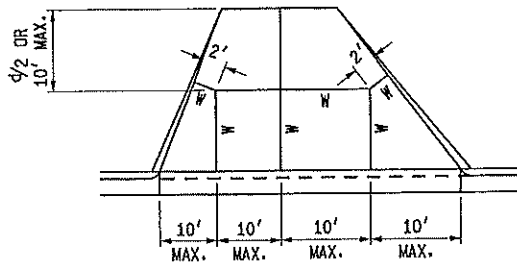

ADJUST DRIVEWAY JOINTS AS NEEDED TO ALIGN WITH ANY COINCIDING TRANSVERSE PAVEMENT JOINTS.

JOINT LAYOUT IS AS INDICATED OR AS DIRECTED BY THE ENGINEER.

INTERMEDIATE DRIVEWAY JOINT DETAILS

REINFORCEMENT FOR CONCRETE DRIVEWAYS

CONCRETE DRIVEWAY THICKNESS	WIRE SIZE (6" x 6" MESH)	AVERAGE WEIGHT (LBS/100 SFT)
LESS THAN 8"	W1.4	21
	W2.9	42
8" OR GREATER	USE WIRE FABRIC REINFORCEMENT SPECIFIED ON STANDARD PLAN R-37-SERIES	

MICHIGAN DEPARTMENT OF TRANSPORTATION
BUREAU OF HIGHWAY DEVELOPMENT STANDARD PLAN FOR

DRIVEWAY OPENINGS & APPROACHES, AND CONCRETE SIDEWALK

9-30-2014
F.H.W.A. APPROVAL

7-1-2014
PLAN DATE

R-29-I

SHEET
3 OF 4

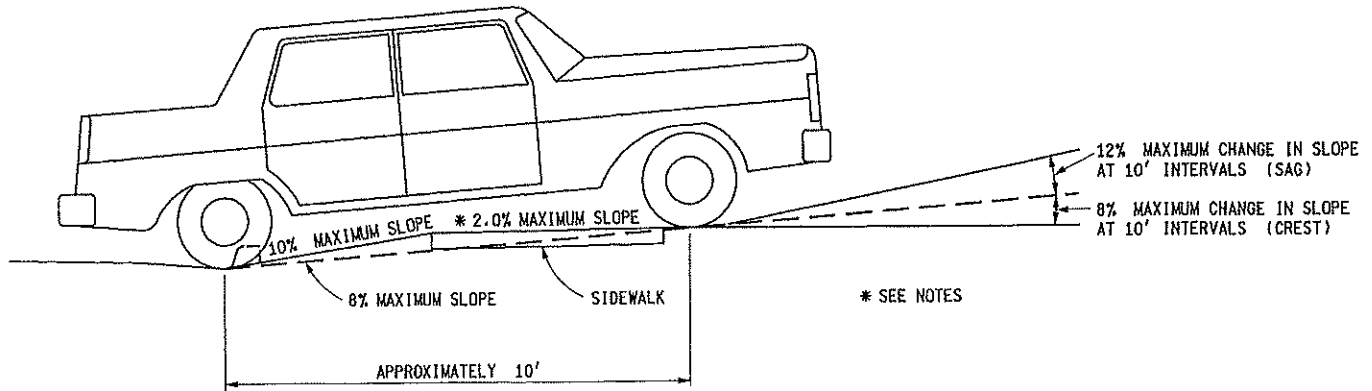

LOW VOLUME COMMERCIAL OR RESIDENTIAL DRIVEWAY SLOPES

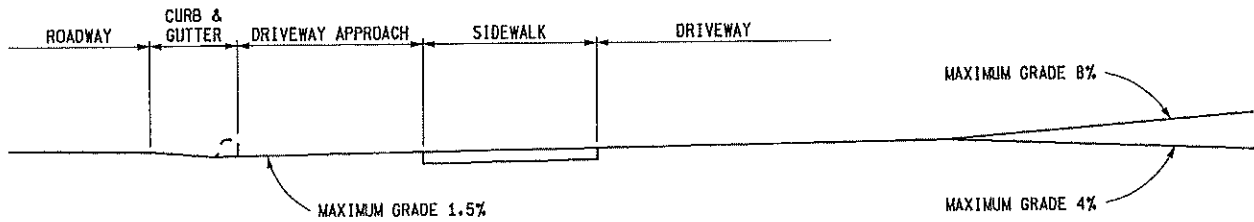

COMMERCIAL DRIVEWAY PROFILE FOR MAJOR TRAFFIC GENERATORS

NOTES:

FOR DRIVEWAY DESIGN REFER ALSO TO "ADMINISTRATIVE RULES REGULATING DRIVEWAYS, BANNERS, AND PARADES ON OR OVER HIGHWAYS" AND GEOMETRIC DESIGN G-680-SERIES, COMMERCIAL DRIVEWAYS.

FOR CURB AND GUTTER DETAILS, SEE STANDARD PLAN R-30-SERIES.

TRANSVERSE SIDEWALK SLOPES ARE TYPICALLY 1.5% (2.0% MAXIMUM). IN ORDER TO MEET SITE CONDITIONS, IF THE TRANSVERSE SLOPE IS REQUIRED TO BE LESS THAN 1.5%, LONGITUDINAL DRAINAGE MUST BE PROVIDED.

WHEN SETTING GRADES FOR COMMERCIAL DRIVES, THE TYPES OF VEHICLES USING THE DRIVE SHOULD BE CONSIDERED.

MICHIGAN DEPARTMENT OF TRANSPORTATION BUREAU OF HIGHWAY DEVELOPMENT STANDARD PLAN FOR DRIVEWAY OPENINGS & APPROACHES, AND CONCRETE SIDEWALK			
9-30-2014 F.H.W.A. APPROVAL	7-1-2014 PLAN DATE	R-29-I	SHEET 4 OF 4